

INJECTION & 3D PRINTED FRAMES → FLEX

INFLEX

WITH FLEXUNO

PATENTED



Print it or mold it – Inflex does it all!

INFLEX

WITH FLEXUNO

60-44064.866

- Short nickel silver spring hinge optionally assembled with front hinge - nickel plated
- Stable U-shape mechanism in stainless steel already pre-assembled
- Zero rocking & easy adjustment with flexUno two-barrel construction

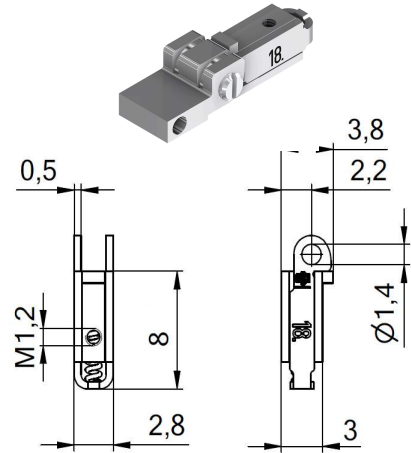

Matching front solutions

90° Front hinge for inserting	Step hinges for soldering	Block hinge for screwing	No front hinge - Direct Joining with DJ screw
33-04164	52-05265	32-04078	99-02907

Matching Screws

Screws to fix Inflex to the temple	99-01436 (ø 2.5) 99-01750 (ø 2.2) 99-02037 (ø 2.2)	
Screws to fix block hinge 32-04078 to the front	99-01752 - 3.7mm 99-02023 - 4.4mm 99-02009 - 4.5 mm 99-02028 - 5.6 mm	
Hinge Screws	99-01816 99-02503 99-04816 99-02591 self aligning	

