

FRAMES MADE FROM SPECIAL MATERIALS → FLEX

Slidex

SLIDING SPRING HINGES



Gliding precision – no matter what material

Slidex

SLIDING SPRING HINGES

60-03088

- Sliding spring hinge
- Case to be fixed with screw on temple
- Made from nickel silver
- Ideal for horn, wood, aluminium, carbon, plastic and other exotic temples
- Milling tool available – 20-47441
- MOQ 100 pairs
- 75% of recycled nickel silver chips are used in the production of new cases

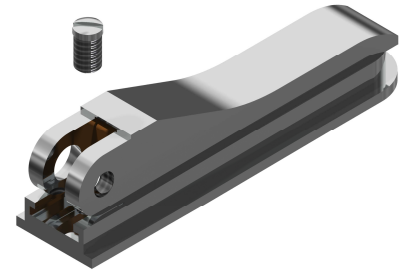

Case width	3.0 mm
Case length	19.0 mm
Slide width	4.5 mm
Slide length	19.5 mm
Material	nickel silver
Joining technique	with screw
Spring mechanism	pre-assembled
Surface finish	nickel plated or gold plated

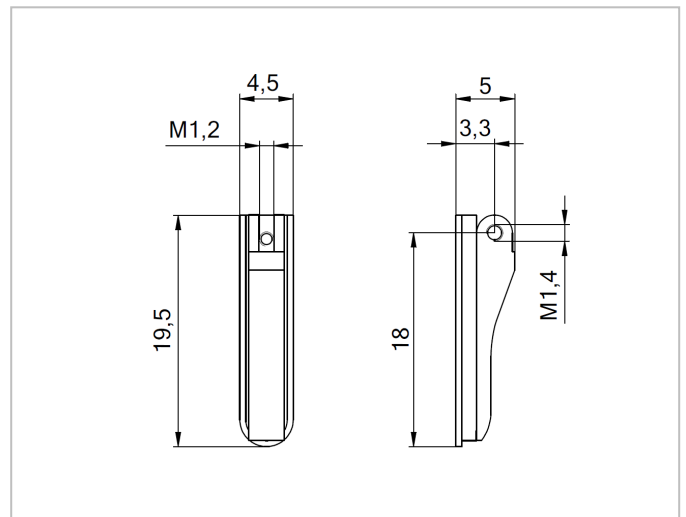

Matching parts

Front hinges for plastic frames 90°	Rivet hinges / Rivets	Hinge screws	Fixation to temple
		<p>Safety</p>	
33-05066	51-05005 11-20247 11-20251 11-20245 11-20246	99-01813 99-02501 99-01539	99-02018

